

AL320

ARTICULATED LOADER



*PREVIEW IMAGE

KEY FEATURES

- 4-Post Open Canopy ROPS and FOPS Certified
- Front Auxillary Hydraulics w/ Flat-Faced Couplers
- Inching Pedal
- Digital Display with Audible and Visual Indicators
- Automotive Style Hydrostatic Drive, 2-Speed
- Perkins Diesel Engine
- Deluxe, Tilttable Steering Column
- Multi-Function Joystick

AL320 ARTICULATED LOADER

SPECIFICATIONS

		IMPERIAL	METRIC
DIMENSIONS	A	Overall Length w/ Bucket Level	161" / 4104 mm
	B	Overall Length - Less Bucket	134" / 3406 mm
	C	Front Wheel Center to Hinge Pin - Arm Down	24" / 617 mm
	D	Wheel Base	65" / 1650 mm
	E	Rear Overhang	39.2" / 995 mm
	F	Overall Height @ ROPS	88.9" / 2258 mm
	H	Height to Top of Hood	55.3" / 1405 mm
	J	Overall Operating Height - Fully Raised, Bucket Rolled Back	130.4" / 3313 mm
	K	Height to Hinge Pin - Fully Raised	99" / 2520 mm
	L	Ground Plane to Bucket Edge Height	89.6" / 2277 mm
	M	Dump Height - Fully Raised	70.9" / 1800 mm
	N	Dump Reach - Fully Raised	13.5" / 344 mm
	O	Digging Position (+Above Ground / -Below Ground)	2.2" / 56 mm
	P	Overall Width - Less Bucket	43.3" / 1100 mm
	Q	Track or Tread Width (Wheel Center)	32.9" / 836 mm
	R	Widest Fixed Point on Machine (ROPS width)	39" / 991 mm
	S	Ground Clearance	12.6" / 320 mm
	T	Clearance Radius - Front w/ Bucket @ Carry Position	127.8" / 3246 mm
	U	Clearance Radius - Less Bucket	108.9" / 2767 mm
	V	Clearance Radius - Inner	63.9" / 1623 mm
	W	Max Articulation Angle	45°
	X	Maximum Rollback Angle - Fully Raised	50°
	Y	Dump Angle - Fully Raised	39°
	Z	Maximum Rollback Angle @ Ground	49°
	AA	Quick-Attach Hinge Pin Ground Clearance (Pin Center)	7.4" / 187 mm
	BB	Height from Ground to Axle Center	8" / 214 mm
	CC	Bucket Width	59.8" / 1520 mm
	Maximum Oscillation Angle	10°	
CAPACITIES		Static Tipping Load with Bucket Straight	4156 lbs / 1885 kg
		Static Tipping Load with Bucket Full Turn	3649 lbs / 1655 kg
		Static Tipping Load with Forks Straight	3064 lbs / 1390 kg
		Static Tipping Load with Forks Full Turn	2690 lbs / 1220 kg
		Bucket Breakout	4442 lbs / 2015 kg
		Transport Weight With 4-Post Canopy	5159 lbs / 2340 kg
ENGINE		Engine Manufacturer	Perkins
		Model / Number of Cylinders	403J-17 / 3
		Net Power @ 2800 rpm	24.7 hp / 18.4 kW
		Maximum Torque / Engine Rotation @ 1800 rpm	62.7 ft/lbs / 85 nM
HYDRAULICS		Work Hydraulic System Flow	7.9 gpm / 30 lpm
		Drive Hydraulic System Pressure	3002 psi / 207 bar
OTHER		Travel Speeds	12.4 / 17.5 mph / 20 / 28 km/hr
		Fuel Tank Capacity	9.2 gal / 35 L
		Tires	US 33 x 15.5 - 16.5 EU 15.0 x 55 - 17

STANDARD FEATURES

- Automotive Style Hydrostatic Drive, 2-Speed
- Counterweight
- Front/Rear Tie Downs
- Heavy-Duty Axles
- Steering/Frame Transport Lock
- Deluxe Instrument Panel
- Battery Disconnect
- Perkins Diesel Engine
- Lockable Engine Cover
- Radiator/Hydraulic Cooler - Side By Side
- Front Auxillary Hydraulics w/ Flat-Faced Couplers
- Adjustable Seat - 5-Way
- Adjustable Seat Belt 2 in. (50 mm)
- Braking/Inching Pedal
- Deluxe, Tilttable Steering Column
- Horn
- Multi-Function Joystick

OPTIONAL FEATURES

- Cabin with Heat
- Differential Locking
- Air suspension seat
- LED Work Lights
- LED Road Lights
- Different wheel options
- Side gates

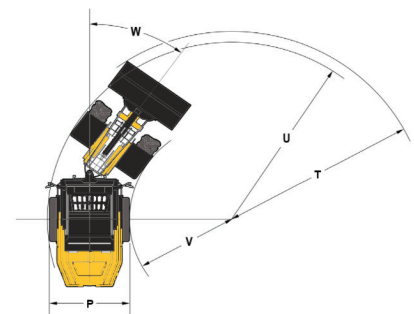
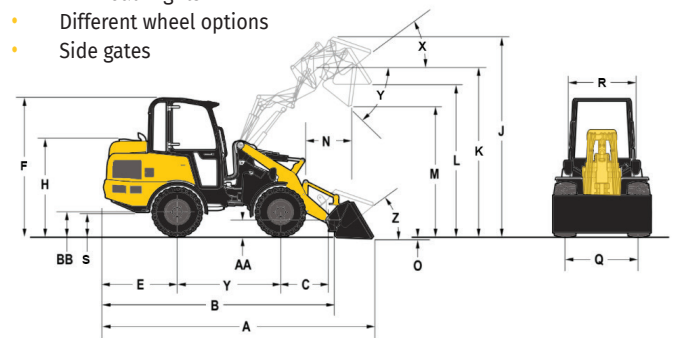

GEHL COMPACT EQUIPMENT

West Bend, WI 53095 U.S.A. | Tel: 262-334-9461 | Fax: 262-338-7517

GEHL Company reminds users to read and understand the operator's manual before operating any equipment. Also, make sure all safety devices and shields are in place and functioning properly.

GEHL reserves the right to add improvements or make changes in specifications at any time without notice or obligation.