

# AL420

ARTICULATED LOADER



\*PREVIEW IMAGE

## KEY FEATURES

- 4-Post Open Canopy ROPS and FOPS Certified
- Front Auxillary Hydraulics w/ Flat-Faced Couplers
- Inching Pedal
- Digital Display with Audible and Visual Indicators
- Automotive Style Hydrostatic Drive, 2-Speed
- Perkins Turbo Charged Diesel Engine
- Deluxe, Tilttable Steering Column
- Multi-Function Joystick

# AL420 ARTICULATED LOADER

## SPECIFICATIONS

		IMPERIAL	METRIC
DIMENSIONS	A	Overall Length w/ Bucket Level	166" 4230 mm
	B	Overall Length - Less Bucket	149" 3531 mm
	C	Front Wheel Center to Hinge Pin - Arm Down	24" 617 mm
	D	Wheel Base	65" 1650 mm
	E	Rear Overhang	44.1" 1120 mm
	F	Overall Height @ ROPS	88.9" 2258 mm
	H	Height to Top of Hood	55.3" 1405 mm
	J	Overall Operating Height - Fully Raised, Bucket Rolled Back	130.4" 3313 mm
	K	Height to Hinge Pin - Fully Raised	99.2" 2520 mm
	L	Ground Plane to Bucket Edge Height	89.6" 2277 mm
	M	Dump Height - Fully Raised	70.9" 1800 mm
	N	Dump Reach - Fully Raised	13.5" 344 mm
	O	Digging Position (+Above Ground / -Below Ground)	2.2" 56 mm
	P	Overall Width - Less Bucket	43.3" 1100 mm
	Q	Track or Tread Width (Wheel Center)	32.9" 836 mm
	R	Widest Fixed Point on Machine (ROPS width)	39" 991 mm
	S	Ground Clearance	12.6" 320 mm
	T	Clearance Radius - Front w/ Bucket @ Carry Position	127.8" 3246 mm
	U	Clearance Radius - Less Bucket	108.9" 2767 mm
	V	Clearance Radius - Inner	63.9" 1623 mm
	W	Max Articulation Angle	45°
	X	Maximum Rollback Angle - Fully Raised	50°
	Y	Dump Angle - Fully Raised	39°
	Z	Maximum Rollback Angle @ Ground	49°
	AA	Quick-Attach Hinge Pin Ground Clearance (Pin Center)	7.4" 187 mm
	BB	Height from Ground to Axle Center	8.4" 214 mm
CC	Bucket Width	59.8" 1520 mm	
	Maximum Oscillation Angle	10°	
CAPACITIES		Static Tipping Load with Bucket Straight	4211 lbs 1910 kg
		Static Tipping Load with Bucket Full Turn	3704 lbs 1680 kg
		Static Tipping Load with Forks Straight	3108 lbs 1410 kg
		Static Tipping Load with Forks Full Turn	2723 lbs 1235 kg
		Bucket Breakout	4442 lbs 2015 kg
		Transport Weight With Canopy	5269 lbs 2390 kg
ENGINE		Engine Manufacturer	Perkins
		Model / Number of Cylinders	403J-E17T / 3
		Net Power @ 2200 rpm	48.3 hp 36 kW
		Maximum Torque / Engine Rotation @ 1600 rpm	122.4 ft/lbs 166 nM
HYDRAULICS		Work Hydraulic System Flow	15.9 gpm 60 lpm
		Drive Hydraulic System Pressure	3002 psi 207 bar
OTHER		Travel Speeds	12.4 / 17.5 mph 20 / 28 km/hr
		Fuel Tank Capacity	9.2 gal 35 L
		Tires	US 33 x 15.5 - 16.5 EU 15.0 x 55 - 17

## STANDARD FEATURES

- Automotive Style Hydrostatic Drive, 2-Speed
- Counterweight
- Front/Rear Tie Downs
- Heavy-Duty Axles
- Steering/Frame Transport Lock
- Deluxe Instrument Panel
- Battery Disconnect
- Perkins Turbo Charged Diesel Engine
- Lockable Engine Cover
- Radiator/Hydraulic Cooler - Side By Side
- Front Auxillary Hydraulics w/ Flat-Faced Couplers
- Adjustable Seat - 5-Way
- Adjustable Seat Belt 2 in. (50 mm)
- Braking/Inching Pedal
- Deluxe, Tilttable Steering Column
- Horn
- Multi-Function Joystick

## OPTIONAL FEATURES

- Cabin with Heat and/or Air Conditioning
- Differential Locking
- 30 km/hr max. speed
- Air suspension seat
- LED Work Lights
- LED Road Lights
- Different wheel options
- Side gates

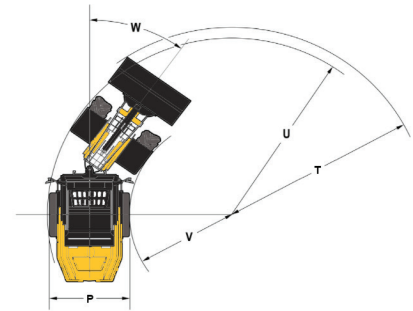
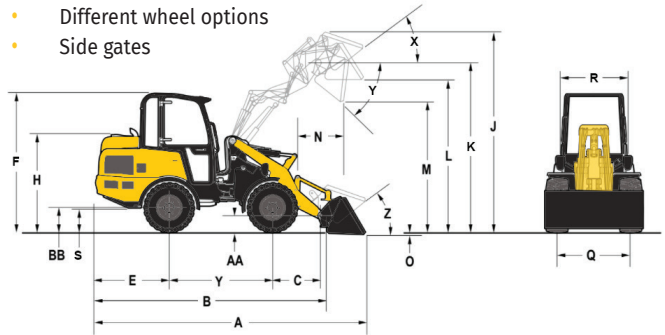

GEHL COMPACT EQUIPMENT

West Bend, WI 53095 U.S.A. | Tel: 262-334-9461 | Fax: 262-338-7517

GEHL Company reminds users to read and understand the operator's manual before operating any equipment. Also, make sure all safety devices and shields are in place and functioning properly.

GEHL reserves the right to add improvements or make changes in specifications at any time without notice or obligation.